

**FIBC FILLING**



**DISCHARGING**

## **DATA SHEET: Hygienic Flo Super Clean FIBC Discharger**

The Flo Super Clean Discharger is designed for the hygienic discharge of materials typically for dairy, food, pharmaceutical and hazardous chemical applications. The patented clamping mechanism seals the bag or liner outlet preventing dust release / product contamination during discharge. Available with 15 - 60° hopper options for all types of material and to suit a wide range of outlet spouted bags.

### **FLO SUPER CLEAN STANDARD FEATURES**

- Fork lift or hoist loaded arrangements.
- Load tested FIBC rigging frame.
- With or without vibration facility to assist material discharge.
- Hopper access door to untie the bag outlet spout.
- With or without patented liner tensioning system.
- Manual clamping mechanism.



### **FLO SUPER CLEAN OPTIONS**

- Volumetric feeder / batch / continuous loss in weight systems.
- Low headroom arrangement – de-mountable FLT loading.
- Containment enclosure to clamping mechanism for increased protection, glove or cuff access.
- Pneumatically operated clamping mechanism.
- Integral 25kg sack tip hopper / dust collector.
- Hazardous area / ATEX models.
- Lined IBC or Octabin discharge arrangements.
- Bag closure Flo Choke device.

## ADVANTAGES

- Easy to use, one man operation.
- Sealed clamp system eliminates dust emission during discharge.
- Prevents product contamination.
- If loose liners are used the FIBC remains uncontaminated and may be reused.
- Sealed liner removal.
- Compact - minimum floor space.
- Easy / quick installation.
- Low maintenance.

## TECHNICAL SPECIFICATION

FIBC (Big Bag):	Lined or unlined
Seam height:	To suit application.
Base:	Up to 980mm square standard
Loops:	Corner or cross corner.
Capacity:	Up to 2000kg standard.
Discharge rate:	Typically upto 10 bags / hour

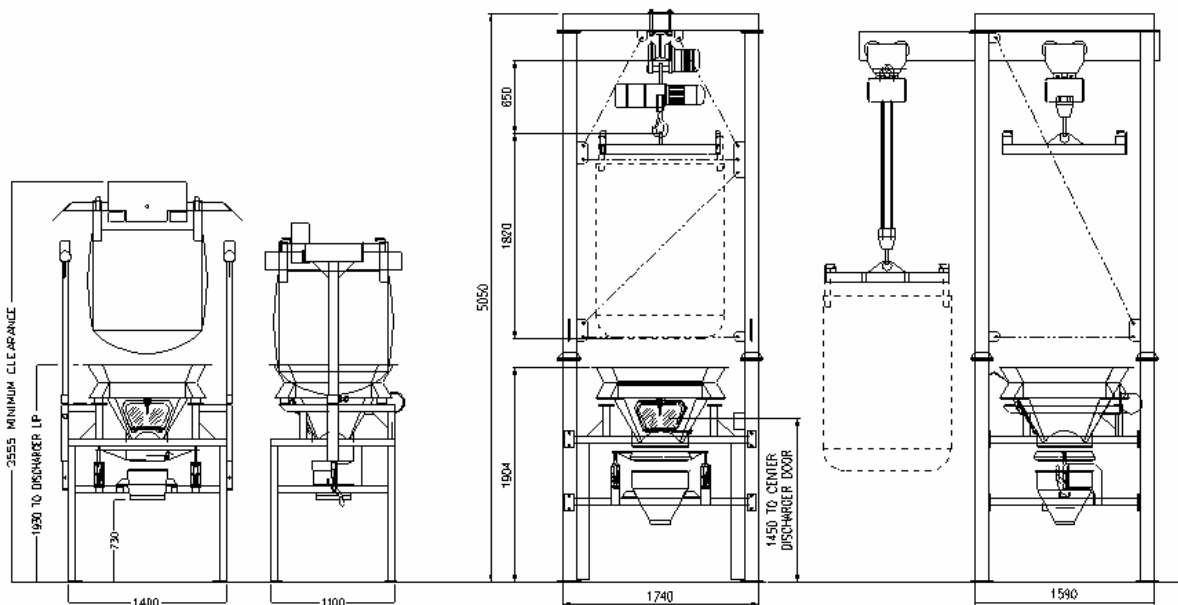

For further information contact:

**Flomat Bagfilla International Ltd**

28 Charles Street

Higher Hillgate

Stockport

SK1 3JR

Tel: 0161 477 4775

Fax: 0161 474 0257

**Email:** [pmhsales@fairport.co.uk](mailto:pmhsales@fairport.co.uk)

**Web:** [www.fairport.co.uk](http://www.fairport.co.uk)



All information contained in this data sheet remains the property of Flomat Bagfilla International. Copying or reproduction of any information is not permitted without prior consent of Flomat Bagfilla. We reserve the right to change or modify information in this document without notice.