

DATA SHEET: Model S30 FIBC (Big Bag) Filling Machine

The S30 has proved to be a very popular filling machine for high throughput and difficult to handle materials. The combination of the patented cone vibration table, and the raise and lower system ensure correct bag shape and maximize bag capacity, producing stable and accurately filled bags.

S30 STANDARD FEATURES

- Filling FIBC's up to 2000kg capacity.
- High accuracy loadcell hang weighing system.
- Volt free contacts for feed device control.
- PLC control system with HMI for easy operator setup.
- Liner inflation system
- Adjustable trombone bag arms and tilting head for easy bag hanging.
- Patented raise and lower cone vibrating table with HMI programmable sequencing.
- Filling head with inflatable bag seal and dust extraction facility.
- Carbon or stainless steel construction.
- Fork Lift truck bag removal.



S30 OPTIONS



- Product feed devices to suit application with controls.
- Plant control and data interfaces.
- Ticket printers.
- Dust collector.
- Hazardous area / ATEX models
- EC approved weighing systems
- Mobile units.
- Pre weigh / check weigh systems.
- Easy height adjustment for different bags.
- Operator platform(s).

ADVANTAGES

- Ideal for difficult to handle materials
- Easy to use, one man operation
- Sealed filling / dust extraction facility
- Easy operator set up via the HMI for different materials / weights
- Handles taller FIBC's
- Fills a wide variety of materials and bag designs.
- High quality build
- Quick / easy installation
- Low maintenance

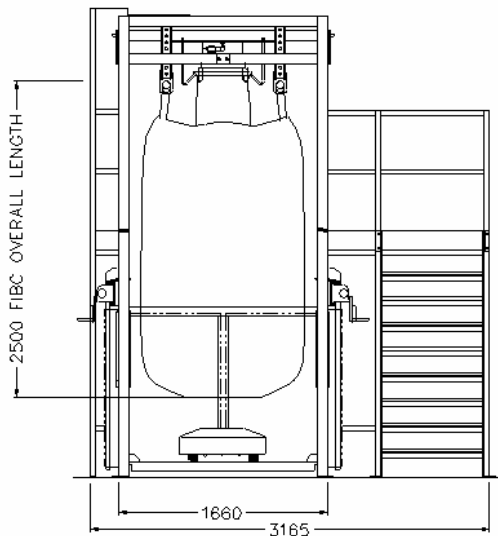

TECHNICAL SPECIFICATION

FIBC (Big Bag) sizes.

Seam height: Up to 2000mm standard.

Base: Up to 1100mm standard.

Loops: Up to 350mm standard.

Capacity: Up to 2000 kg standard.

Weighing system Typical =
1000kg x 0.5kg increments

Bags / hour =

Up to 15 bags / hour (free flowing materials)

Up to 30 bags / hour (pre-weigh-max)

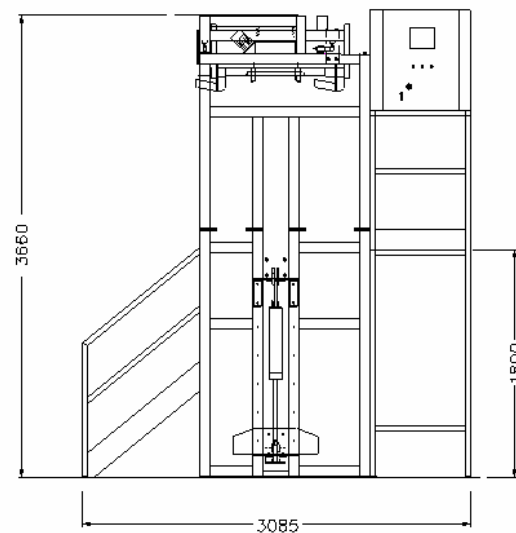

Typical for upto 2000mm seam height bags with vibration table.

For further information contact:

Flomat Bagfilla International Ltd

28 Charles Street

Higher Hillgate

Stockport

SK1 3JR

Tel: 0161 477 4775

Fax: 0161 474 0257

Email: pmhsales@fairport.co.uk

Web: www.fairport.co.uk



fairport

PROCESS MATERIALS HANDLING DIVISION

All information contained in this data sheet remains the property of Flomat Bagfilla International. Copying or reproduction of any information is not permitted without prior consent of Flomat Bagfilla. We reserve the right to change or modify information in this document without notice.