

## DATA SHEET: Pharmaceutical FIBC Discharger

The Pharmaceutical Discharger is designed for the exacting standards required by this industry sector with totally sealed contained and contamination free discharge, high quality construction with flexibility to meet specific customer requirements.

### PHARMACEUTICAL DISCHARGER STANDARD FEATURES

- Hoist, pillar lift or powered truck options.
- Load tested rigging frame.
- With or without vibration facility to assist material discharge.
- Hopper access door to untie the bag outlet spout.
- With or without patented liner tensioning system.
- Manual clamping mechanism.
- Containment enclosure to clamping mechanism.
- Containment levels down to  $25\mu\text{g}/\text{m}^3$
- Liner disposal port.
- Dust extraction facility.
- Polished finishes.
- 316L stainless steel product contact parts.



### PHARMACEUTICAL DISCHARGER OPTIONS

- Glove or slotted membrane access to enclosure.
- HEPA air inlet filter to enclosure.
- Primary and HEPA exhaust air filter assembly.
- Nitrogen purging.
- Bag earth proving system.
- Low headroom arrangement – de-mountable powered truck loading.
- Volumetric feeders / batch / continuous loss in weight systems.
- Bag evacuation / bag collapsing.
- CIP cleaning.
- Pneumatically operated clamping mechanism.
- Hazardous area / ATEX models.
- Bag closure Flo Choke device.



## ADVANTAGES:

- Easy to use, one man operation.
- Contained discharge / eliminates dust emission.
- Prevents product contamination.
- Compact - minimum floor space.
- Easy / quick installation.
- Low maintenance.

FIBC (Big Bag): Fixed or loose lined bags  
Seam height: To suite application.  
Base: Up to 980mm square standard.  
Loops: Corner or cross corner.  
Capacity: Up to 2000kg standard  
Containment: Down to  $25\mu\text{g}/\text{m}^3$

## TECHNICAL SPECIFICATION:

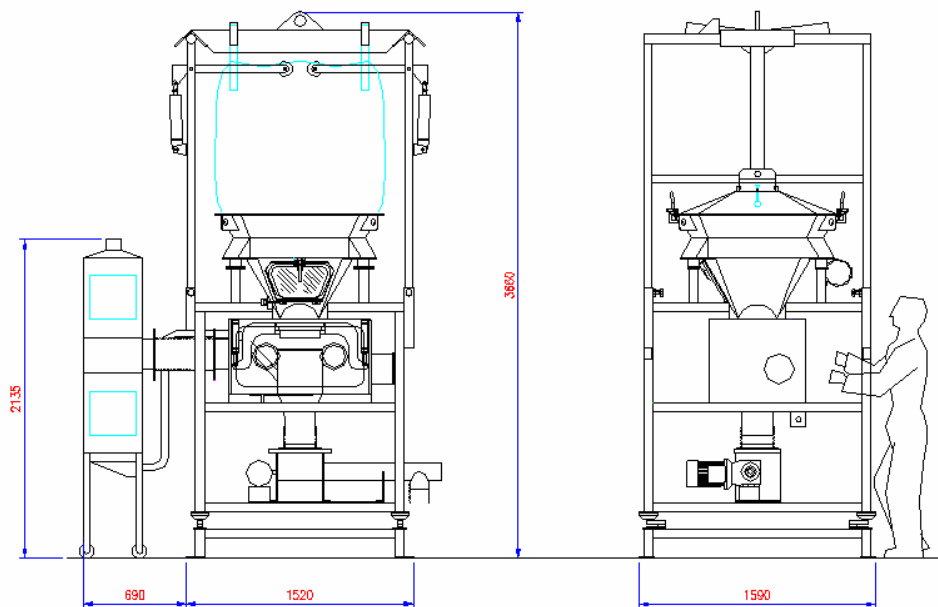

For further information contact:

### Flomat Bagfilla International Ltd

28 Charles Street

Higher Hillgate

Stockport

SK1 3JR

Tel: 0161 477 4775

Fax: 0161 474 0257

Email: [info@fairport.co.uk](mailto:info@fairport.co.uk)

Web: [www.fairport.co.uk](http://www.fairport.co.uk)



All information contained in this data sheet remains the property of Flomat Bagfilla International. Copying or reproduction of any information is not permitted without prior consent of Flomat Bagfilla. We reserve the right to change or modify information in this document without notice.